



NDL Industries

APPLICATIONS

Commercial, Industrial, and Residential CO₂ Refrigeration

Stainless Steel Service Ball Valves (CO₂-HS)

NDL CO₂ ball valves perform unlike any other in its class for leak prevention, reliability, and superior field performance.



CO₂-HS Specifications

Exceptional Safety Margins

Our valves can hold *five times* their maximum working pressure, netting a tremendous safety margin for any ball valve used in CO₂ systems.

Quality Tested

Each valve is helium tested at the factory to guarantee leak-free performance.

Bottom-Up Stem Installation

Our stem placement is engineered from the bottom up. If there is an accidental over-pressurization in the valve, it will not blow the stem out and lose the charge.

Stainless Steel Body

The NDL CO₂ valves feature a stainless steel body for stainless steel connections.

Size and Connections

A wide range of sizes and connection types makes our valves compatible with main pipe types manufactured from copper iron alloys and stainless steel.

Unparalleled Two-year Warranty

Our warranty proves confidence, along with stamping every valve with a serial number and cleanly packaging in a poly-bag to prevent contamination and malfunctions.



Stainless Steel Service Ball Valves

Operating Specifications

- Temperature: -40° to 302°F (-40°C to 150°C)
- Burst Pressure: 5 times the working pressure
- Life Expectancy: >50,000 cycles

Certifications and Approvals

- CE
- RoHS
- UL-Listed
- CRN Approved

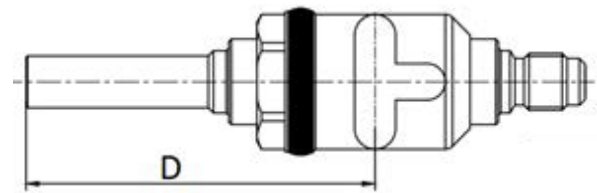
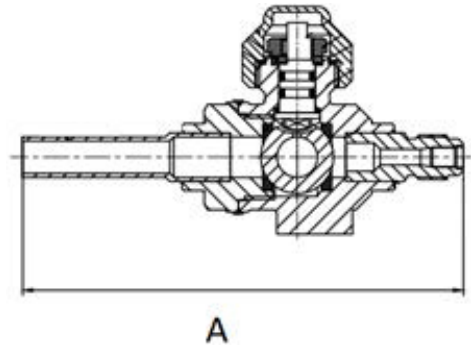
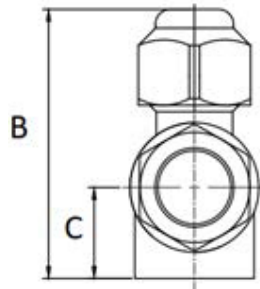

CO₂-HS Dimensions

PART NUMBER	CONNECTIONS		BALL PORT SIZE	KV	CV	MAXIMUM OPERATING PRESSURE	
	W, MM	SAE, IN	MM	M3/H	GPM	BAR	PSI
CO2-HS10	10	1/4"	10	1.1	1.3	140	2030
CO2-HS12	12	1/4"	10	1.1	1.3	140	2030